



Industrial Ball Valves



(Optional Oval Handle- Uninstalled)

Index

2-Piece Ball Valve 7510	1
3-Piece Ball Valve 7520	2
3-Piece Ball Valve with Gyrolok® Tube End Fittings 7520	3
High Tolerance Thread Specification	4

industrial ball valves

Family Features

- Low Pressure Design for Non-Critical Service
- Includes High Tolerance NPT Thread or Unique Gyrolok Tube Connections
- Stainless Steel Construction
- Locking Handles

HOKE Incorporated

405 Centura Court • PO Box 4866 (29305) • Spartanburg, SC 29303
Phone (864) 574-7966 Fax (864) 587-5608
www.hoke.com • sales@hoke.com

2-Piece Standard Port Ball Valves

Threaded Ends, 2000 PSI (138 Bar) W.O.G.

Features

- Reinforced TFE seats increase durability
- Adjustable packing gland
- Bottom-loaded blow-out proof stem
- Basic design complies with ANSI B16.34 & EN 12516-1
- High Tolerance NPT Thread Specification
- Tested according to API 598
- Lever Style handle with locking device
- Part Number and Brand embossed on the body
- Tapped Mounting Pad

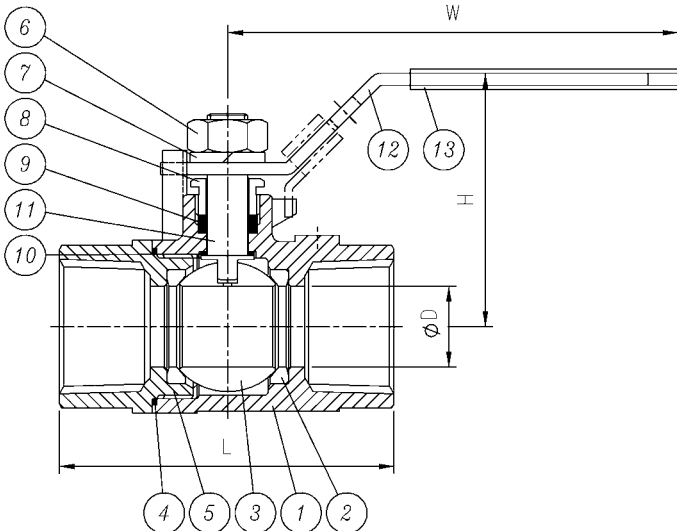
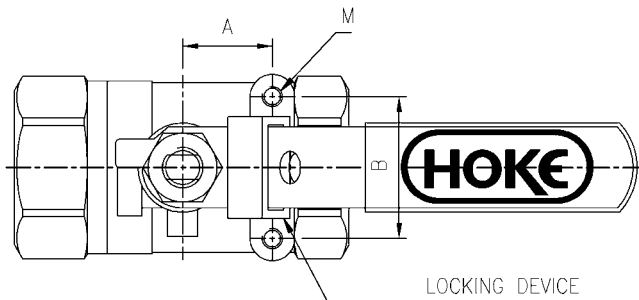

Materials List

PARTS	7510F (X)Y	
1	Body	ASTM A351-CF8M/316
2	Seat	Reinforced PTFE
3	Ball	ASTM A351-CF8M/316
4	Gasket	PTFE
5	End Cap	ASTM A351-CF8M/316
6	Handle Nut	AISI 304
7	Handle Washer	AISI 304
8	Gland	AISI 304
9	Stem Packing	PTFE
10	Thrust Washer	PTFE
11	Stem	ASTM A276-316
12	Handle	AISI 304
13	Handle Cover	PVC

How To Order:

PART #	SIZE	ØD	L	A	B	H	W	M
7510F4Y	inch - ¼"	0.37	2.09	0.50	1.12	2.13	3.70	10-24UNC
7510F6Y	inch - ⅜"	0.37	2.09	0.50	1.12	2.13	3.70	10-24UNC
7510F8Y	inch - ½"	0.49	2.38	0.50	1.12	2.13	3.70	10-24UNC
7510F12Y	inch - ¾"	0.59	2.70	0.50	1.12	2.24	3.70	10-24UNC
7510F16Y	inch - 1"	0.79	3.25	0.87	1.38	2.46	4.37	10-24UNC
7510F20Y	inch - 1¼"	0.98	3.58	0.93	1.38	2.87	5.37	10-24UNC
7510F24Y	inch - 1½"	1.26	3.94	0.93	1.50	3.09	5.37	1/4-20UNC
7510F32Y	inch - 2"	1.50	4.61	0.93	1.50	3.48	6.57	1/4-20UNC

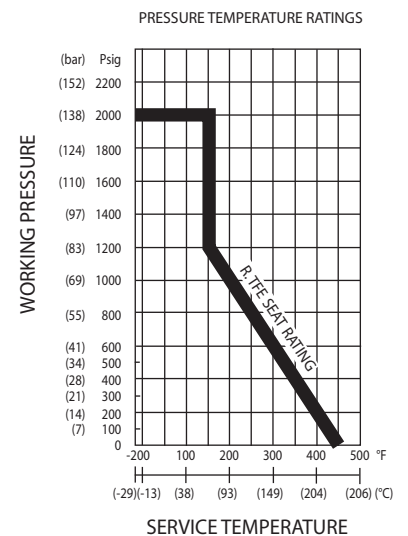

3-Piece Full Port Ball Valves

Threaded Ends, 1/4" - 1/2": 3000PSI (207 Bar) W.O.G.,
 3/4"-1": 2000PSI (138 Bar) W.O.G. Enclosed Bolt Type,
 ISO 5211 Direct Actuator Mounting Pad

Features

- Strengthened construction fully complied with ASME/ANSI B16.34 secures 3000 psi/2000 psi working pressure rating.
- Fully encapsulated bolts are protected from the environment for extended service life.
- Live-loaded packing gland design for self-adjustment of packing compression.
- Equalized cavity pressure hole drilled in the stem slot of ball.
- Bottom-loaded blow-out proof stem.
- Pressure equalizing seats
- Basic design complies with ANSI B16.34.
- Tested according to API 598
- High tolerance NPT Thread Specification
- Part number and brand embossed on body
- **Optional oval handle available (uninstalled)**

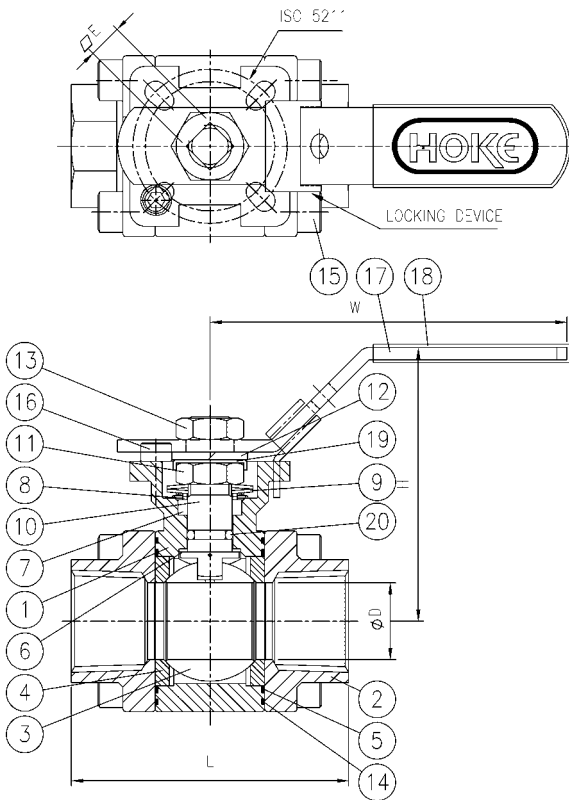

Materials List

PARTS-	7520F (X)Y
1	Body ASTM A351-CF8M/316
2	End Cap ASTM A351-CF8M/316
3	Ball ASTM A351-CF8M/316
4	Seat TFM4215
5	Gasket PTFE
6	Thrust Washer PTFE
7	Stem Packing Graphite
8	Gland AISI 304
9	Belleville Washer AISI 301
10	Stem ASTM A276-316
11	Packing Nut AISI 304
12	Spring Washer AISI 304
13	Handle Nut AISI 304
14	Gasket Graphite
15	Bolt AISI 304
16	Stop Screw AISI 304
17	Handle AISI 304
18	Handle Cover PVC
19	Nut Lock AISI 304
20	O-Ring Viton

How To Order

PART #	SIZE	ØD	L	E	H	W	ISO 5211	OPTIONAL OVAL HANDLE
7520F4Y	inch - 1/4"	0.43	2.62	0.35	2.68	5.31	F03-F04	7520F4Y-OH
7520F6Y	inch - 3/8"	0.49	2.62	0.35	2.68	5.31	F03-F04	7520F6Y-OH
7520F8Y	inch - 1/2"	0.59	2.76	0.35	2.68	5.31	F03-F04	7520F8Y-OH
7520F12Y	inch - 3/4"	0.59	3.15	0.35	2.78	5.31	F03-F04	7520F12Y-OH
7520F16Y	inch - 1"	1.00	3.54	0.43	3.50	6.50	F04-F05	7520F16Y-OH

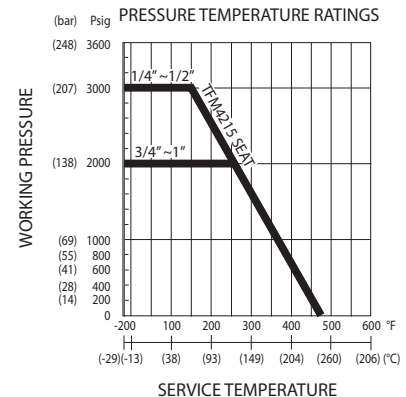

3-Piece Full Port Ball Valves

Gyrolok End Tube Fittings, 1/4" - 1/2": 3000PSI (207 Bar)
 W.O.G., 3/4"-1": 2000PSI (138 Bar) W.O.G. Enclosed
 Bolt Type, ISO 5211 Direct Actuator Mounting Pad



Features

- Strengthened construction fully complied with ASME/ANSI B16.34 secures 3000 psi/2000 psi working pressure rating.
- Fully encapsulated bolts are protected from the environment for extended service life.
- Live-loaded packing gland design for self-adjustment of packing compression.
- Equalized cavity pressure hole drilled in the stem slot of ball.
- Bottom-loaded blow-out proof stem.
- Pressure equalizing seats
- Basic design complies with ANSI B16.34.
- Tested according to API 598
- Gyrolok® Tube Fitting End Connections
- Part number and brand embossed on body
- **Optional oval handle available (uninstalled)**

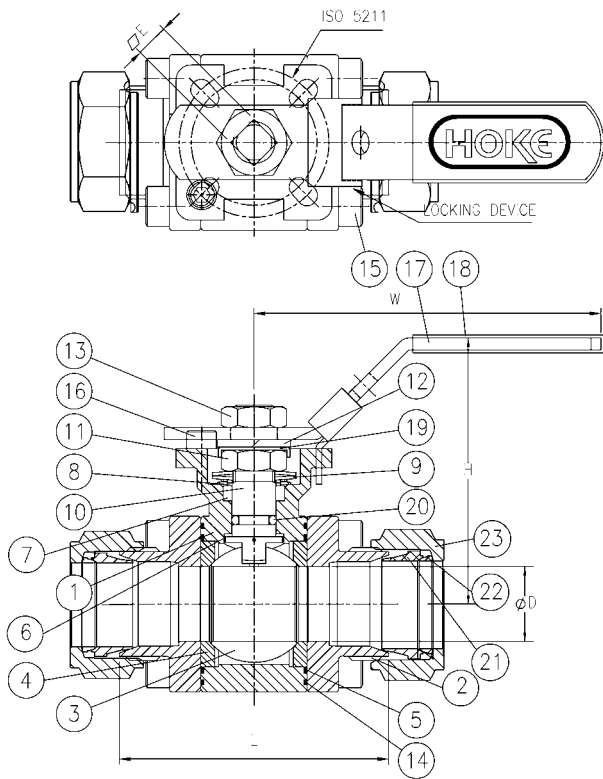

Materials List

PARTS -	7520G (XY)
1	Body ASTM A351-CF8M/316
2	End Cap ASTM A351-CF8M/316
3	Ball ASTM A351-CF8M/316
4	Seat TFM4215
5	Gasket PTFE
6	Thrust Washer PTFE
7	Stem Packing Graphite
8	Gland AISI 304
9	Belleville Washer AISI 301
10	Stem ASTM A276-316
11	Packing Nut AISI 304
12	Spring Washer AISI 304
13	Handle Nut AISI 304
14	Gasket Graphite
15	Bolt AISI 304
16	Stop Screw AISI 304
17	Handle AISI 304
18	Handle Cover PVC
19	Nut Lock AISI 304
20	O-Ring Viton

How To Order

PART #	SIZE	ØD	L	E	H	W	ISO 5211	OPTIONAL OVAL HANDLE
7520G4Y	inch - 1/4"	0.43	2.62	0.35	2.68	5.31	F03-F04	7520G4Y-OH
7520G6Y	inch - 3/8"	0.49	2.62	0.35	2.68	5.31	F03-F04	7520G6Y-OH
7520G8Y	inch - 1/2"	0.59	2.76	0.35	2.68	5.31	F03-F04	7520G8Y-OH
7520G12Y	inch - 3/4"	0.59	3.15	0.35	2.78	5.31	F03-F04	7520G12Y-OH
7520G16Y	inch - 1"	1.00	3.54	0.43	3.50	6.50	F04-F05	7520G16Y-OH

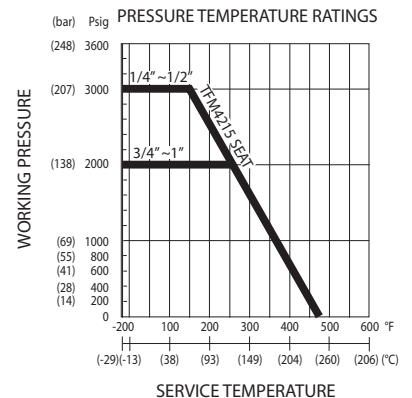

NPT High Tolerance Thread Specification

NPT Engagement using High Tolerance HOKE NPT Connections has 5-6 threads engaged when fully tightened.

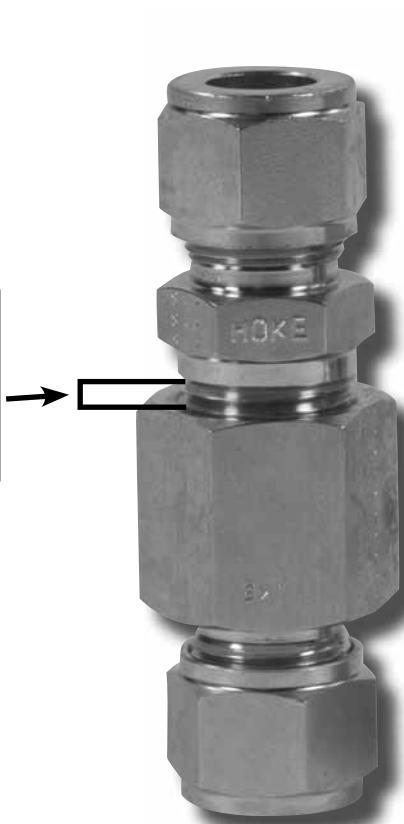

**HOKE High Tolerance
NPT Thread**

NPT Engagement using ANSI/ASME B1.20.1 Pipe Thread Standard has only 3-4 threads engaged when fully tightened.

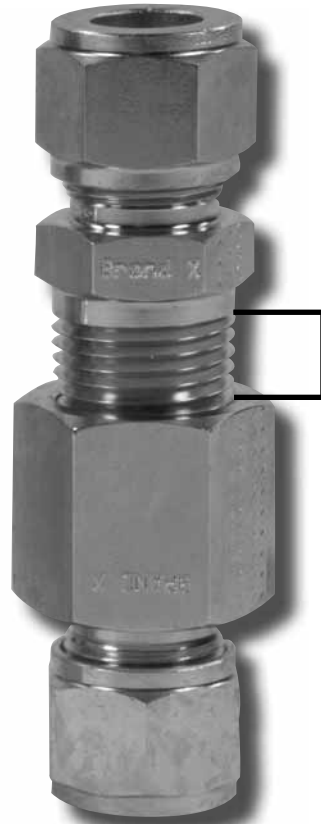

**Standard B1.20.1
NPT Thread**

Tube Fittings

In the early 1960's, HOKE took the industry by storm, introducing the GYROLOK® tube fitting. To this day, the design features offer unique advantages and benefits to users that are unmatched in the industry.

Key GYROLOK® Design Benefits:

1) Controlled Ferrule Drive and Sizing Angle

- Avoids risks associated with over-tightening and allows for multiple remakes

2) Butt Seal

- Provides an extra level of protection against leaks

3) Special high tolerance NPT thread specification

- Ensures maximum thread engagement for a safer, more robust connection.

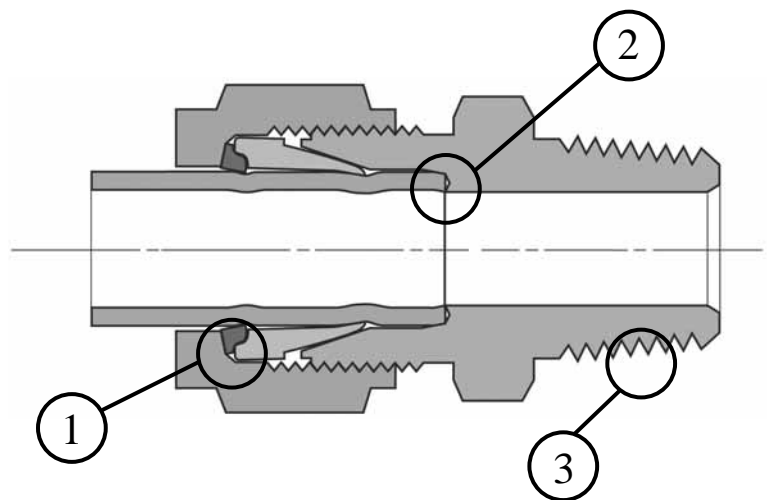

CIRCOR

Instrumentation Technologies

Our Company

CIRCOR Instrumentation Technologies (CIT) is the logical choice for fluid control solutions. We provide the lowest cost of ownership, offering the best in class reliability and availability of our products. We have global coverage, delivering value in the form of local, flexible service to meet our customer's needs. CIT is a product group specializing in instrumentation with orifice sizes typically up to 2".



Our corporate head office and ISO 9001:2000 registered manufacturing facilities are located at 405 Centura Court, Spartanburg, SC, USA, 29303
Tel +1-864-574-7966 • Fax +1-864-587-5608
www.hoke.com • www.circortechnologies.com

Proudly Distributed By:

