

# MCR-1CLP-I-I-00

Order No.: 2814016



<http://eshop.phoenixcontact.de/phoenix/treeViewClick.do?UID=2814016>

MCR passive isolator, for the electrical isolation of current signals without auxiliary power, 1-channel, input signal: 0(4)...20 mA, output signal: 0(4)...20 mA



Commercial data	
GTIN (EAN)	 4 017918 131722
sales group	H505
Pack	1 pcs.
Customs tariff	85437090
Catalog page information	Page 369 (IF-2009)

### Product notes

WEEE/RoHS-compliant since:  
09/03/2007



<http://www.download.phoenixcontact.com>  
Please note that the data given here has been taken from the online catalog. For comprehensive information and data, please refer to the user documentation. The General Terms and Conditions of Use apply to Internet downloads.

## Technical data

Input data	
Description of the input	Current input
Configurable/programmable	No
Current input signal	0 mA ... 20 mA
	4 mA ... 20 mA

Max. input voltage	30 V (30 V overload)
Max. input current	50 mA (100 mA overload)
Response current	< 50 $\mu$ A
Input voltage limitation	33 V (with Zener diode)
Voltage dissipation	2.5 V (at I = 20 mA)

#### Output data

Output name	Current output
Configurable/programmable	No
Current output signal	0 mA ... 20 mA 4 mA ... 20 mA
Max. output current	< 50 mA
Load/output load current output	$\leq 1375 \Omega$ (at I = 20 mA output signal)

#### Power supply

Supply voltage range	(no separate supply voltage necessary)
----------------------	--

#### Connection data

Type of connection	Pluggable screw connection
Conductor cross section solid min.	0.2 mm <sup>2</sup>
Conductor cross section solid max.	2.5 mm <sup>2</sup>
Conductor cross section stranded min.	0.2 mm <sup>2</sup>
Conductor cross section stranded max.	2.5 mm <sup>2</sup>
Conductor cross section AWG/kcmil min.	24
Conductor cross section AWG/kcmil max	14
Stripping length	8 mm
Screw thread	M3

#### General data

No. of channels	1
Width	12.5 mm
Height	99 mm
Depth	114.5 mm
Maximum transmission error	$\leq 0.1 \%$ (of final value)
Maximum temperature coefficient	$\leq 0.002 \%/K$ (of measured value / 100 $\Omega$ load)
Additional error, load-dependent	0.02 % (of measured value)
Limit frequency (3 dB)	< 75 Hz

Step response (10-90%)	5 ms (with 500 Ω load)
Ambient temperature (operation)	-10 °C ... 70 °C
Degree of protection	IP20
Test voltage input/output	510 V (50 Hz, 1 min.)
Color	green
Housing material	Polyamide PA non-reinforced
Mounting position	Any
Conformance	CE-compliant
UL, USA / Canada	cULus

**Certificates / Approvals**



Certification

CUL, GOST, UL

**Diagrams/Drawings**

Application drawing



Application example: - flow measurement  
 1 = magnetic inductive flow gauge  
 2 = control

Diagram

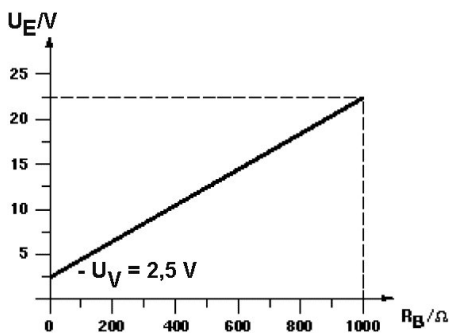

Dimensioned drawing

---

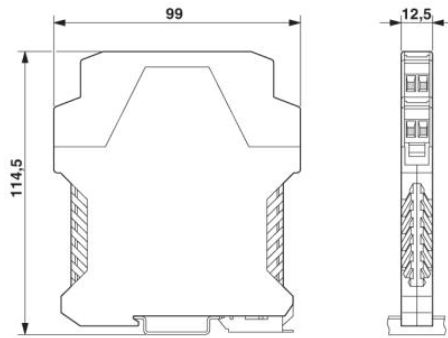

Circuit diagram

---

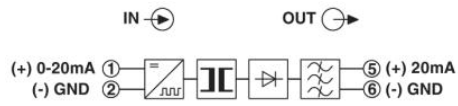

**Address**

PHOENIX CONTACT Inc., USA  
586 Fulling Mill Road  
Middletown, PA 17057, USA  
Phone (800) 888-7388  
Fax (717) 944-1625  
<http://www.phoenixcon.com>



© 2010 Phoenix Contact  
Technical modifications reserved;